



ROFU® ELECTRIC STRIKE MODEL 1508

1508 - SERIES, FACEPLATE SIZE 1 $\frac{1}{8}$ " x 5 $\frac{7}{8}$ "

MODEL 1508 — Fail - Secure (Non Fail - Safe)

Electric strikes for use with cylindrical locksets.

For Commercial and Residential, New and Retrofit Uses



1508
Non-Handed

Standard Features

- Zinc/Aluminum Alloy Faceplate
- Frame Type - Hollow Metal, Aluminum or Wood
- Corrosion - Resistant case and moving parts.
- Tamper Strength Test - 1000 lbs (454kg)
- Cycle Test 500,000 cycles
- Keeper Depth - **5/8"** Maximum Latch Projection possible with 1/8" Door/Frame Clearance - **3/4"**
- Strike Depth 1.43" Overall
- Reversible - Non Handed
- Limited Warranty - **36 Months**

Available in the following Voltages and Finishes:

Specify Finish xUS28
Voltage, Fail Secure x01=8-16VAC/3-6VDC
 x05=12VAC/12VDC
 x08=24VAC/24VDC



LINE ART FOR 1508

WOOD JAMB PREPARATION

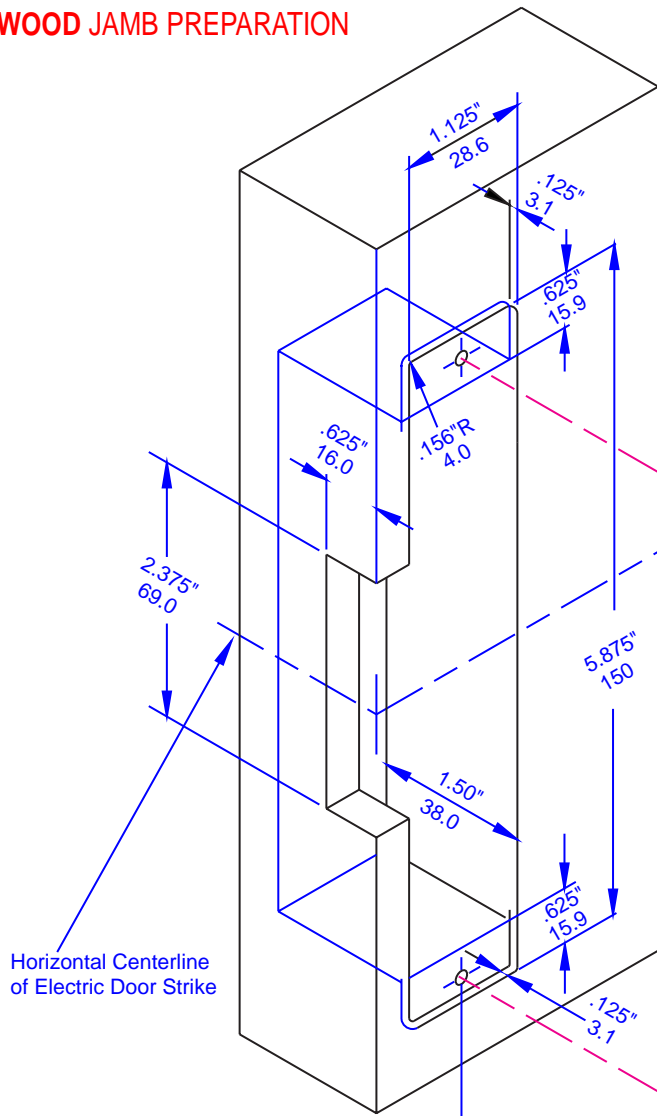

Horizontal Centerline of Electric Door Strike

The mounting screws of the electric strike and the mounting screws of the deadlatch are located on the vertical centerline.

INSTALLATION

